

ITEM #	PART #	QTY	DESCRIPTION
1	SRE-001	2	END ASSEMBLY
2	SR-001	4	WHEEL
3	SRM-001	1	MIDDLE ASSEMBLY
4	SRR-001	(SRA-6) - 6 (SRA-8) - 8 (SRA-10) - 10	ROLLER ASSEMBLY
5	LC-001	10	LOCKING BRACKET
6	LB-001	20	ROTATION LOCK BRACKET
7	-	24	.375 LOCK WASHER
8	-	16	3/8-16 NUT
9	-	8	.375 X 1.75 BOLT (MMC# 92865A630)
10	-	16	.375 WASHER
11	-	8	.375 NUT (MMC# 94811A031)
12	-	30	.25-20 NUT (MMC# 94811A029)
13	-	10	.25 X 1.5 HEX BOLT (MMC# 92865A546)
14	-	10	.25-20 LOCK WASHER

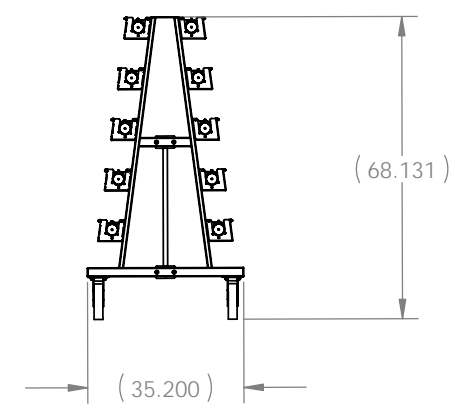
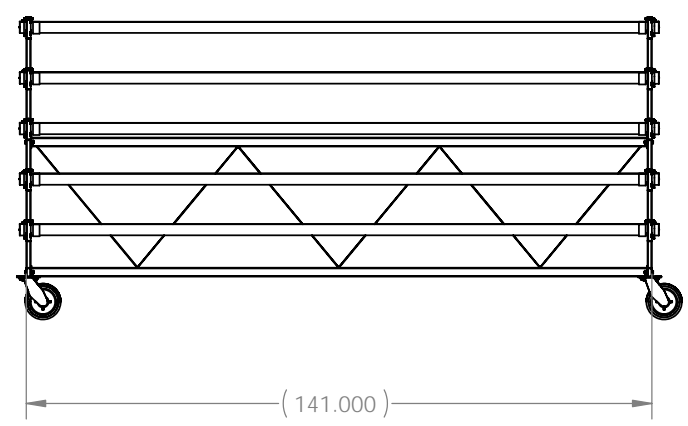
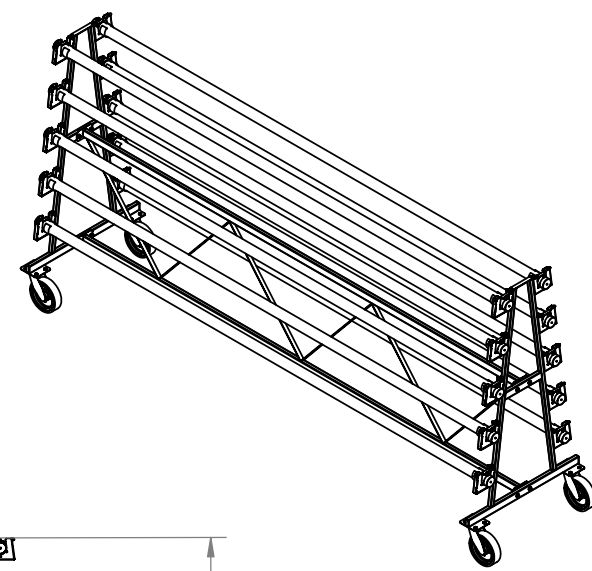

**PROPRIETARY AND CONFIDENTIAL**  
 THE INFORMATION CONTAINED IN THIS DRAWING IS THE SOLE PROPERTY OF <INSERT COMPANY NAME HERE>. ANY REPRODUCTION IN PART OR AS A WHOLE WITHOUT THE WRITTEN PERMISSION OF <INSERT COMPANY NAME HERE> IS PROHIBITED.

		UNLESS OTHERWISE SPECIFIED:		NAME	DATE	<b>REVERE PLASTICS</b> TITLE: <b>SPORTS ROLLER</b> SIZE <b>B</b> DWG. NO. <b>SRA-XX</b> REV <b>A</b> SCALE: 1:32 WEIGHT: SHEET 1 OF 4	
		DIMENSIONS ARE IN INCHES		DRAWN	LC		5-2-6
		TOLERANCES:		CHECKED			
		FRACTIONAL ±		ENG APPR.			
		ANGULAR: MACH ± BEND ±		MFG APPR.			
		TWO PLACE DECIMAL ±.020		Q.A.			
		THREE PLACE DECIMAL ±.010		COMMENTS:			
		INTERPRET GEOMETRIC TOLERANCING PER:					
		MATERIAL:					
		FINISH:					
NEXT ASSY	USED ON						
APPLICATION		DO NOT SCALE DRAWING					

8 7 6 5 4 3 2 1

**STEP 1**

ASSEMBLE (4) WHEELS (ITEM 2) ONTO BOTH END ASSEMBLIES (ITEM 1) USING (16) .375 LOCK WASHERS (ITEM 7) AND (16) 3/8-16 NUTS (ITEM 8), AS SHOWN.

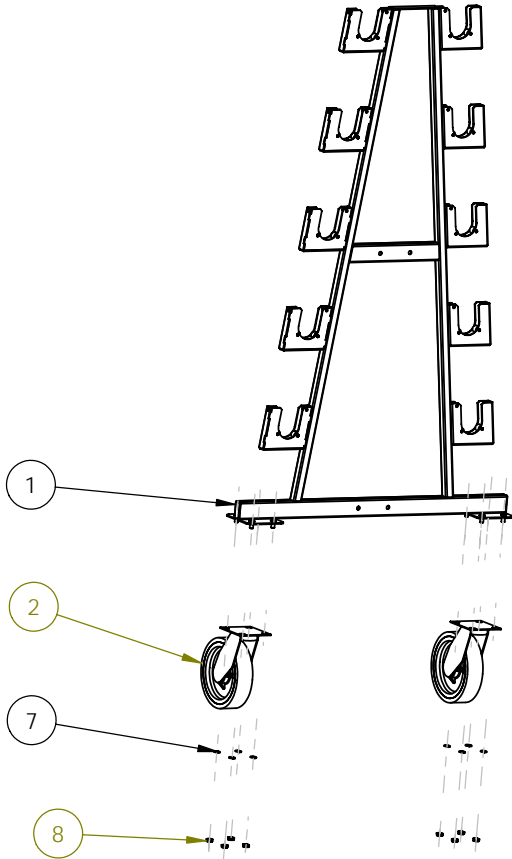

**STEP 2**

ASSEMBLE (2) END ASSEMBLIES (ITEM 1) TO MIDDLE ASSEMBLY (ITEM 3) USING (8) .375 X 1.75 BOLTS (ITEM 9), (16) .375 WASHERS, (8) .375 LOCK WASHERS, AND (8) .375 NUTS (ITEM 11), AS SHOWN.

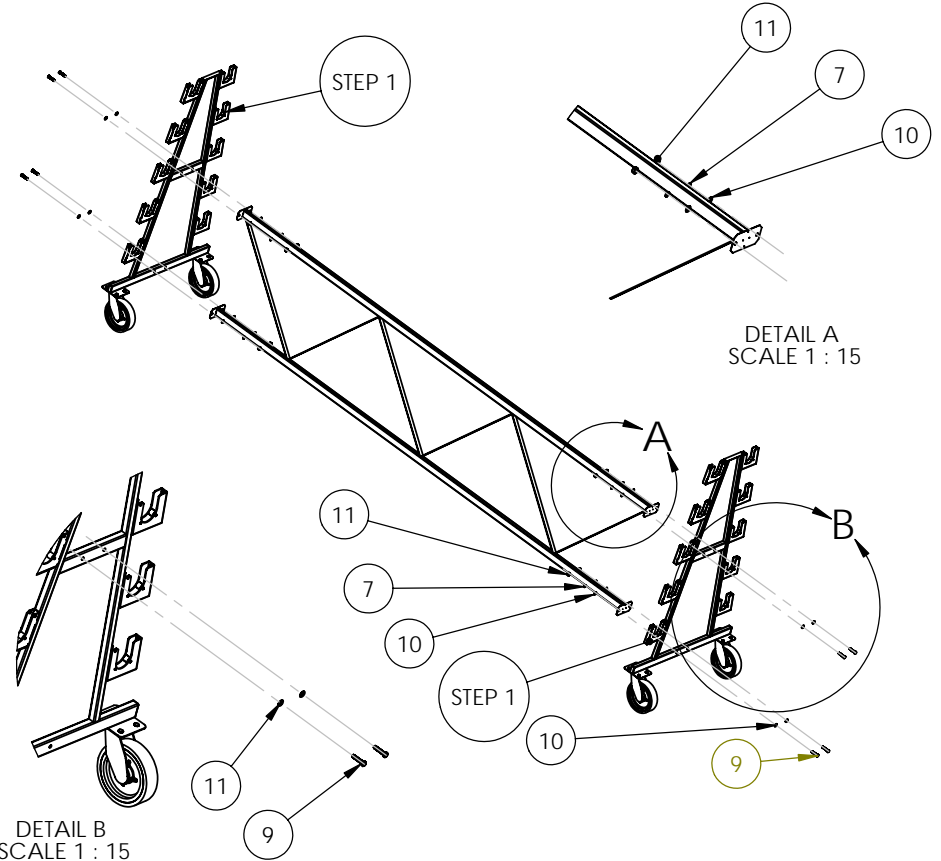

**PROPRIETARY AND CONFIDENTIAL**  
 THE INFORMATION CONTAINED IN THIS DRAWING IS THE SOLE PROPERTY OF <INSERT COMPANY NAME HERE>. ANY REPRODUCTION IN PART OR AS A WHOLE WITHOUT THE WRITTEN PERMISSION OF <INSERT COMPANY NAME HERE> IS PROHIBITED.

		UNLESS OTHERWISE SPECIFIED:	NAME	DATE	<b>REVERE PLASTICS</b>	
		DIMENSIONS ARE IN INCHES	LC	5-2-6		TITLE:
		TOLERANCES:				<b>SPORTS ROLLER</b>
		FRACTIONAL ±				SIZE DWG. NO. REV
		ANGULAR: MACH ± BEND ±			<b>B SRA-XX A</b>	
		TWO PLACE DECIMAL ± 0.00			SCALE: 1:48 WEIGHT:	
		THREE PLACE DECIMAL ± 0.010			SHEET 2 OF 4	
		INTERPRET GEOMETRIC TOLERANCING PER:	COMMENTS:			
		MATERIAL:				
		FINISH:				
NEXT ASSY	USED ON	DO NOT SCALE DRAWING				
APPLICATION						

8 7 6 5 4 3 2 1

8 7 6 5 4 3 2 1

**STEP 3**

ASSEMBLE ROLLER ASSEMBLIES (ITEM 3, SEE BELOW FOR QUANTITY) IN STEP 2.

- SRA-6 - 6 ROLLER ASSEMBLIES
- SRA-8 - 8 ROLLER ASSEMBLIES
- SRA-10 - 10 ROLLER ASSEMBLIES

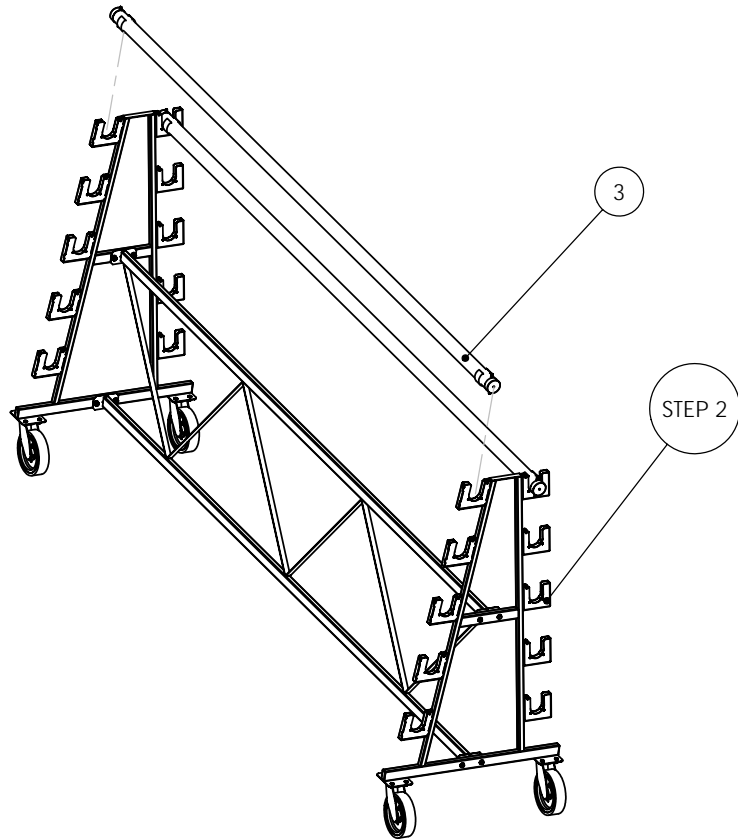

**PROPRIETARY AND CONFIDENTIAL**  
 THE INFORMATION CONTAINED IN THIS DRAWING IS THE SOLE PROPERTY OF <INSERT COMPANY NAME HERE>. ANY REPRODUCTION IN PART OR AS A WHOLE WITHOUT THE WRITTEN PERMISSION OF <INSERT COMPANY NAME HERE> IS PROHIBITED.

**STEP 4**

ASSEMBLE ROLLER RETAINER (ITEM 6) ONTO ROLLER SUPPORTS USING .25-20 HEX NUT (ITEM 12) AS SHOWN. (20 PLACES)

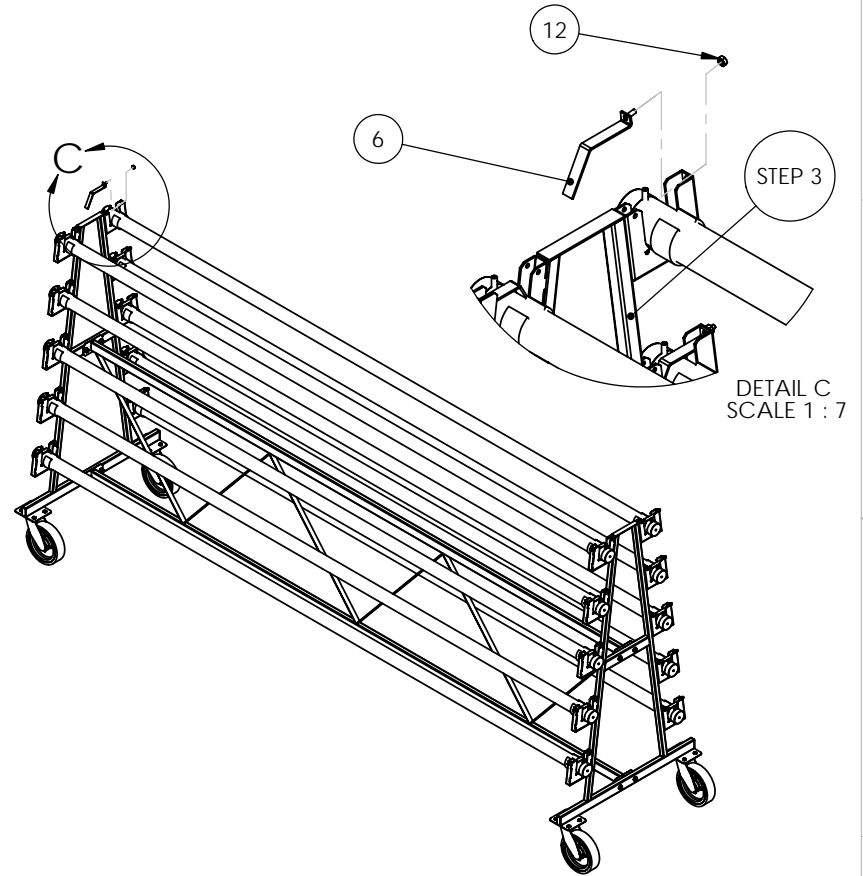

		UNLESS OTHERWISE SPECIFIED:		NAME	DATE	<b>REVERE PLASTICS</b> TITLE: <b>SPORTS ROLLER</b> SIZE DWG. NO. REV <b>B SRA-XX A</b> SCALE: 1:48 WEIGHT: SHEET 3 OF 4	
		DIMENSIONS ARE IN INCHES		DRAWN	LC		5-2-6
		TOLERANCES:		CHECKED			
		FRACTIONAL ±		ENG APPR.			
		ANGULAR: MACH ± BEND ±		MFG APPR.			
		TWO PLACE DECIMAL ±.020		Q.A.			
		THREE PLACE DECIMAL ±.010		COMMENTS:			
		INTERPRET GEOMETRIC TOLERANCING PER:					
		MATERIAL:					
		FINISH:					
NEXT ASSY	USED ON						
APPLICATION		DO NOT SCALE DRAWING					

8 7 6 5 4 3 2 1

8 7 6 5 4 3 2 1

**STEP 4**

ASSEMBLE ROTATION LOCK BRACKET (ITEM 5) TO ROLLER SUPPORTS USING .25-20 LOCK WASHER (ITEM 14) AND .25-20 HEX NUT (ITEM 12), WHERE SHOWN (10 PLACES).

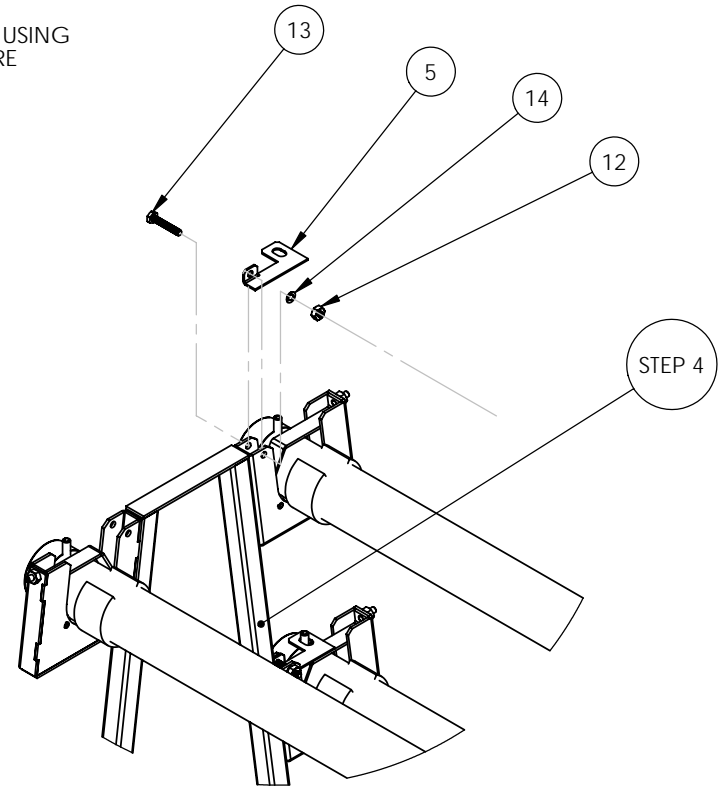
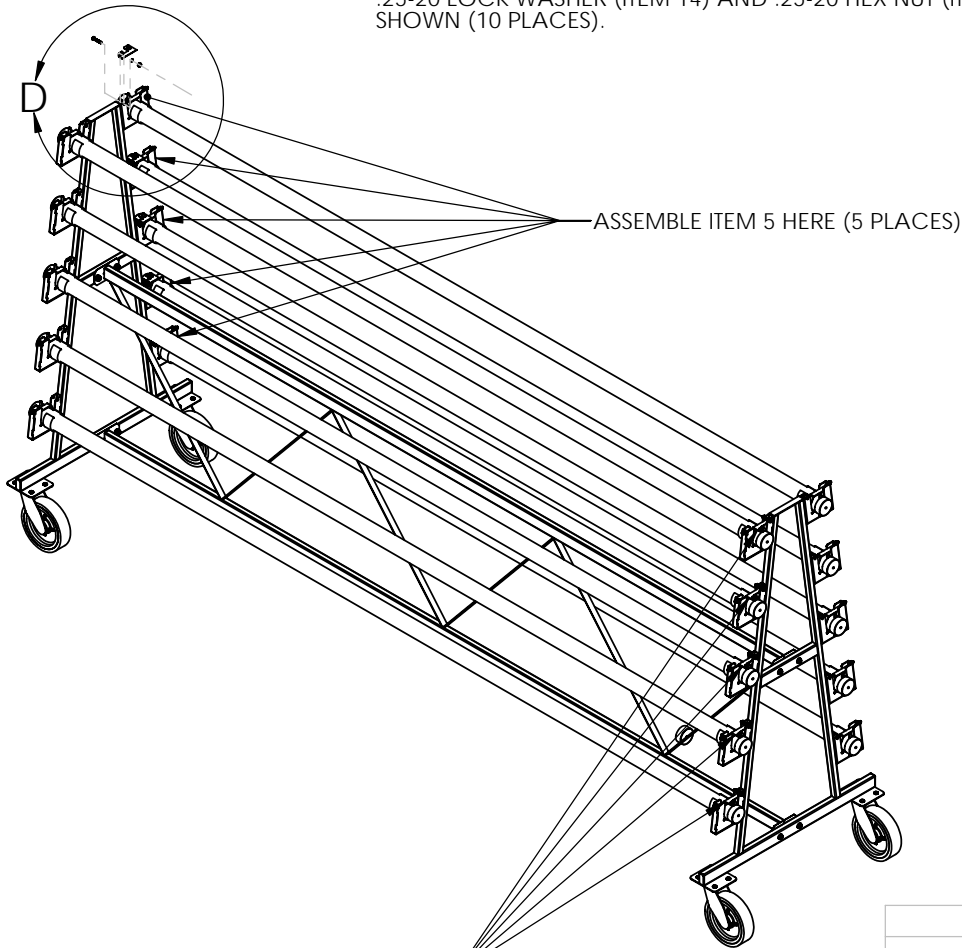

DETAIL D  
SCALE 1 : 5

ASSEMBLE ITEM 5 HERE (5 PLACES)

**PROPRIETARY AND CONFIDENTIAL**  
THE INFORMATION CONTAINED IN THIS DRAWING IS THE SOLE PROPERTY OF <INSERT COMPANY NAME HERE>. ANY REPRODUCTION IN PART OR AS A WHOLE WITHOUT THE WRITTEN PERMISSION OF <INSERT COMPANY NAME HERE> IS PROHIBITED.

		UNLESS OTHERWISE SPECIFIED:		NAME	DATE	<b>REVERE PLASTICS</b>
		DIMENSIONS ARE IN INCHES		DRAWN	LC	
		TOLERANCES:		CHECKED		TITLE:
		FRACTIONAL ±		ENG APPR.		<b>SPORTS ROLLER</b>
		ANGULAR: MACH ± BEND ±		MFG APPR.		Q.A.
		TWO PLACE DECIMAL ±.020		COMMENTS:		SIZE
		THREE PLACE DECIMAL ±.010				DWG. NO.
		INTERPRET GEOMETRIC TOLERANCING PER:				REV
		MATERIAL:				<b>A</b>
		FINISH:				SCALE: 1:48
NEXT ASSY	USED ON	DO NOT SCALE DRAWING				WEIGHT:
						SHEET 4 OF 4

8 7 6 5 4 3 2 1